

INSTALLATION INSTRUCTION MECHANICAL ROAD DISC BRAKE SYSTEM

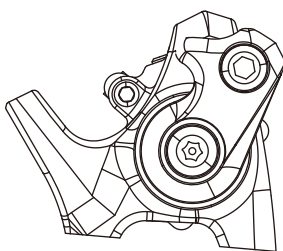

TOOLS NEEDED FOR ASSEMBLY AND MAINTENANCE

- 5mm hex wrench
- 4mm hex wrench
- 3mm hex wrench
- T25 Torx® wrench
- Cable housing cutters
- Cable cutters

SAFETY WARNINGS & INFORMATION

- WARNING** - This braking system was designed for use on a single rider bicycle. Use of this system on any other vehicle or apparatus will void the warranty, possibly causing you great personal harm or injury.
- WARNING** - Disc Brakes, calipers, and rotors get VERY HOT during regular use. DO NOT touch or attempt to service the rotor or caliper assembly until you've allowed for sufficient cooling to occur.
- WARNING** - These disc brakes offer a significant increase in performance over traditional cable actuated systems. Follow the break-in recommendations listed in this manual, allow yourself to learn and become accustomed to the braking characteristics.
- WARNING** - If your bike is involved in a fall or crash, fully check the brake function including: the lever, caliper, and rotor are securely attached to the bike, pads are correctly installed and functioning, the cable is operating smoothly and the lever feels firm when actuating the brake.
- Always have a qualified mechanic check the brakes if you have any doubts.
- WARNING** - Pad thickness must be at least 0.8 mm of pad material. Confirm this before each ride. Keep pads clean and free of oil or hydraulic fluid. If pads become contaminated, discard and replace.
- WARNING** - Ensure that cable housing is always secured to the frame and/or fork prior to every ride. Do not ride a bike on which the cable housing can come into contact with the tires!
- CAUTION** - Read this manual completely before attempting to install or work on your TRP brakes. If you are unfamiliar with any element of assembly or maintenance of this braking system please consult a qualified mechanic for assistance.
- CAUTION** - Cleanliness is a very important part of any maintenance of a TRP disc brake. If the pads or rotor become contaminated with oil, or if the system becomes contaminated with impurities, braking performance will be greatly impaired.

ADAPTER INSTRUCTION CHART

FM1.1 F140/F160 Adapter **F-5**

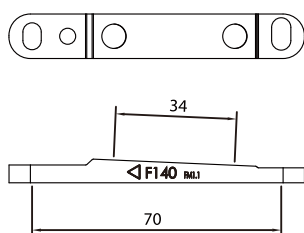

- A** M5x13, 2pcs
- B** M5x14, 2pcs

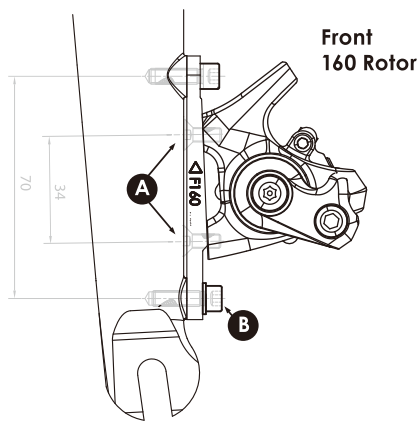
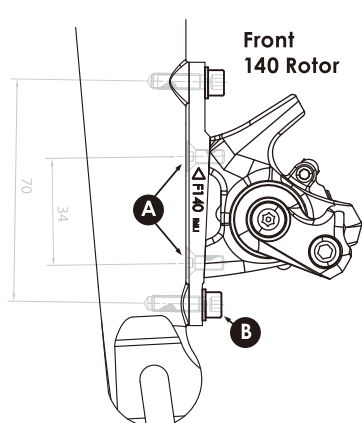

FM1.1 R160 Adapter **F-6**

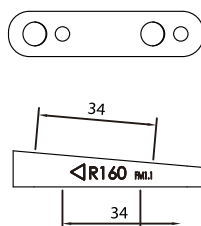

- A** M5x13, 2pcs
- C** M5 Mounting bolt, 2pcs

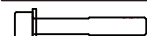

also available
M5x17 M5x37
M5x22 M5x42
M5x27

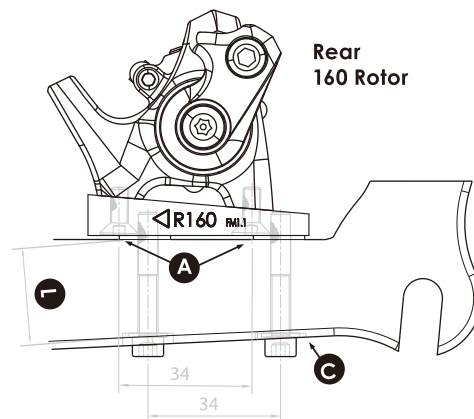

Torque spec:
FlatMount bolts: 5-7 Nm (44-62 in-lb)
Disc Rotor bolts: 4-6 Nm (35-53 in-lb)

M5 BOLT FOR REAR

Bolt = Fork + 7mm

Fork (L)	10	15	20	25	30	35
Bolt (C)	17mm	22mm	27mm	32mm	37mm	42mm

BRAKE SET-UP

HOUSING INSTALLATION

- Compressionless housing, (linear strand) is recommended for Mechanical Road Disc Brakes to yield the best performance. Sealed ferrules or other sealing systems are not recommended as they may create excess friction and affect the brake lever return performance. Route housing to minimize tight bends and acute angles.
- Install a small section of spiral wound housing that inserts into the brake lever body and runs inside or outside the first bend of the bar as shown in B-1, B-2. (Not all brake lever bodies need a ferrule installed - check with your brake lever manufacturer's technical documents to determine if a ferrule is needed.) The ends should be filed flat and the liner should be open to eliminate friction. Install a double-ended ferrule. [ref. B-1, B-2]
- Note: Spiral wound housing can be cut to accommodate bar widths and preferences, such as hiding the double-ended ferrule under the bar wrap. Allow spiral wound housing to extend at least 25mm (1 inch) beyond the handlebar bend. [ref. B-3]
- Install the compressionless housing on the remainder of the frame or fork. Cut appropriately to minimize tight bends and acute angles to optimize the brake lever feel.

CONNECTING THE BRAKE

- Turn barrel adjuster so that it is fully threaded in. Install ferrule on the end of the compressionless housing to fit in the barrel adjuster.
- Run cable through and attach to Mechanical Road Disc Brakes actuator arm. Pull cable tightly, but do not preload. [ref. D-1]
- To align the caliper, re-install the wheel with rotor installed. Pull the brake lever firmly to self-align the caliper on the rotor. Lightly tighten each bolt, alternating between the two and checking alignment. Continue until torque limit is reached, 6 – 8 Nm (53 – 71 in lbs). If you have a pad gap tool, this greatly helps in eliminating pad/rotor noise due to alignment issues.
- Release the lever and check that the pads are aligned equally and that the wheel spins freely. The barrel adjuster may be used to take out cable slack.
- Pull brake lever 10 times to stretch cable and seat housing. Push back on the action arm - if it is not returning fully, this indicates there is too much friction that will need to be corrected for best performance. [ref. D-2 & D-3]
- New cable will stretch after initial installation. Repeat cable tightening process to maintain proper performance.

FINE TUNING

There are two ways to fine-tune the caliper to improve lever feel: the barrel adjuster and the pad adjuster.

- Thread the barrel adjuster out to take up cable slack or compensate for pad wear.
- Using a 5mm hex wrench, turn the pad adjustment screw clockwise to compensate for pad wear or improve lever feel. There is a pad adjust screw on located on inboard pistons. [ref. E-1]

INSTALLING AND REMOVING BRAKE PADS

CHANGING BRAKE PADS

- Remove wheel from bike.
- Pull the cotter pin from the brake pad retaining bolt – be careful not to lose this piece – and loosen the bolt with a 3mm hex wrench. Set the bolt and cotter pin aside. [ref. F-1]
- Slowly pull the bolt out of its sleeve while placing your palm over the rotor end of the brake pads to catch them when they are released. Be careful to save the spring assembly for later use.
- Remove the pads from the bottom end of the caliper.
- Install new pads and spring assembly into the calipers. [ref. F-2]
- Reinsert brake pad retainer bolt into the caliper and re-attach the cotter pin. Tighten the brake pad assembly bolt.
- Repeat for other caliper and adjust cable or pad alignment if necessary.

BREAK-IN PERIOD

BREAK IN PERIOD

- Disc brakes have a 30-40 cycle break-in period to achieve optimal pad seating and performance. Exercise caution for the first 30-40 cycles each time you replace the brake pads.

SAFETY CHECK

Before Every Ride

- Spin Wheel to be sure rotor is undamaged and aligned.
- Check brake pad thickness, if pads are less than 0.8mm replace.
- Check bolt tension, re-torque if necessary.
- Check cable and housing for fraying, excessive friction or damage.
- Ensure that all cables are secured to frame and/or fork and can not contact tires!

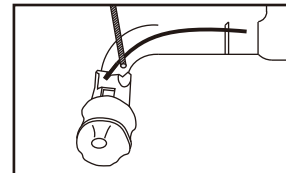

B-1 Check if ferrule is needed on your brand brake lever.

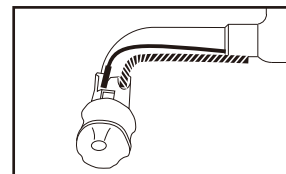

B-2 Install spiral wound housing for handlebar bend

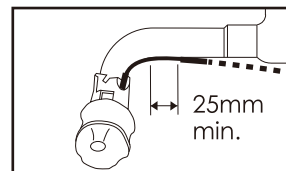

B-3 Housing min. length

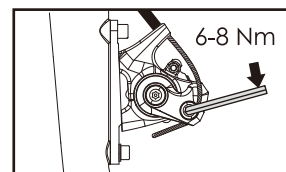

D-1 Pull cable and tighten

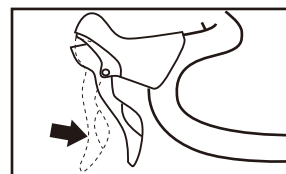

D-2 Squeeze lever 10 times

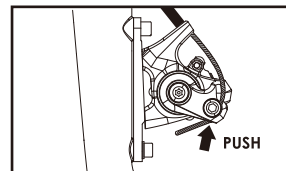

D-3 Check arm return

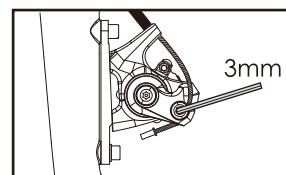

E-1. Pad adjustment screw

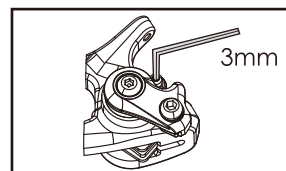

F-1. Unscrew pad retainer bolt

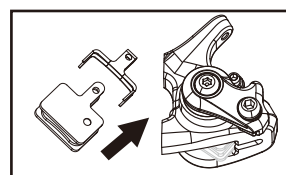

F-2. Replace pads and holder

TEKTRO

www.tekro.com
June, 2016
(English)

000907LY2.0